

## Main Parameter ( Standard Equipment )

Item	Specifications	Item	Specifications
<b>Overall parameter</b>		Speed at FI(km/h)	0~13
Operating weight(kg)	5250	Speed at RI(km/h)	0~19
Rated load(kg)	1600	Speed at RII(km/h)	0~33
L x W x H(mm)	5765×2080×2925	<b>Hydraulic system of working device</b>	
Bucket capacity(m³)	0.8	System pressure(MPa)	18
Max.tractive force(kN)	≥50	Total cycle time(bucket lift & dump&fall )(s)	≤8.3
Max.breakout force(kN)	47	<b>Steering system</b>	
Tipping load(kN)	≥30	System pressure(Mpa)	16
<b>Engine</b>		<b>Fill capacity</b>	
Rated power@speed(kW@r/min)	61.8@2400	Fuel(L)	90
Maximum torque@speed(Nm@r/min)	291 @ (1500 ~ 1800)	Hydraulic oil(L)	52
Emission standard	GB 20891-2014	Engine(L)	7.5
<b>Transmission system</b>		Transmission(L)	20
Transmission type	Fixed shaft power shift	Drive axle(L)	2×9
Gears	F4 & R4	Braking system(L)	4
Speed at FI (km/h)	0~7		

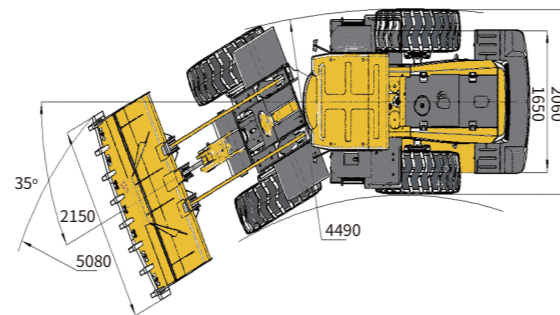
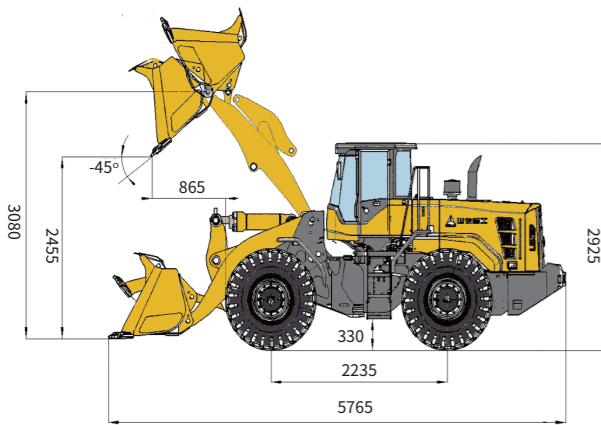

# L916H WHEEL LOADER

Operation Weight: 5250 kg  
Bucket Capacity: 0.8 m<sup>3</sup>  
Engine Power: 61.8 kW

Reliability in Action



**EFQM**

Congratulations SDLG for winning  
**EFQM Global Excellence Award**  
One of the top three quality awards in the world

**Member of the VOVLO Group since 2007**

SDLG is a member of the Volvo Group and one of the largest manufacturers of construction machinery in China, with a wide network of dealerships and service workshops throughout the world.

**Shandong Lingong Construction Machinery Co.,Ltd**

Add: Lingong Industry Park, Economic Development Zone, Linyi, Shandong, P, R, C.  
Tel: 0086-531-66590966 Fax: 0086-531-66590959 E-mail: export@sdlg.com.cn



# L916H Wheel Loader

## RELIABILITY

- Yunnei electronic-controlled China Tier III engine, The specific power-matching technology with P,S,E (heavy-load, medium-load, light-load) power control mode, which can be reasonably selected according to the operating conditions. Not only ensure the machine dynamic performance, but also reduce the energy consumption and improve the productivity
- It is equipped with ZL20A casting reinforced drive axle, It is equipped with large modulus spiral bevel gear and planetary gear. The main drive and hub reduction use dual seals which have good sealing effect, strong bearing capacity and high reliability.
- The heavy-duty front and rear frames use high-strength steel plates which applies with CAE finite element analysis technology. The structure is reasonable, with strong bearing capacity and high reliability.

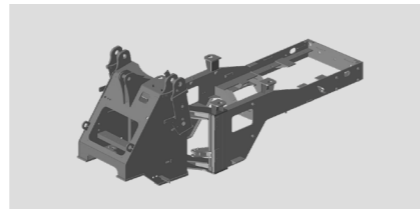

## HIGH EFFICIENCY

- Optimum design of work device. Reasonable matching of hydraulic system. Short total time. High work efficiency
- The dual high-low speed reinforced transmission has great traction and strong power output High travel speed is suitable for long-distance transfer operations
- The bucket is designed according to large-size wheel loader's concept, which has small insertion resistance, and high full-load rate

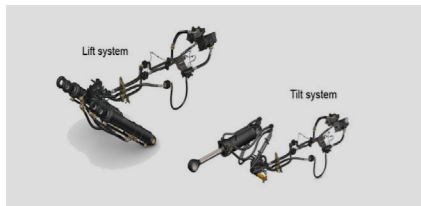

## COMFORT

- New appearance cab has large-size loader style. The dimension is increased and the operation space is large. Dual curved front glass gives you wide vision. No threshold design, equipped with luxurious mechanical suspension seat and comfortable ride
- Three-stage vibration reduction in engine, transmission, and cab. Low vibration, low noise, and more comfortable Digital stepping instrument panel and CAN data bus communication technology. High definition, complete functions, good human-machine interaction
- Newly-designed engine hood with beautiful appearance, frame structure, stable and reliable. Large opening door structure with wide maintenance space. Optional air conditioner and heater, providing drivers with a comfortable operating environment

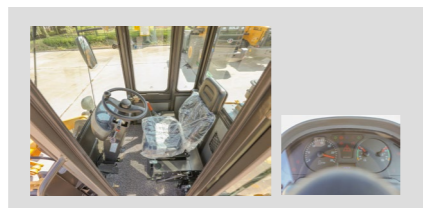

## Standard Configurations

YUNNEI 4EZ080-30CR engine	Centralized control box	<b>C</b>
Transmission type Counter-shaft power shift	Front & rear wiper	
Shifting gears forward 4 reverse 4	Work lights	<b>D</b>
1.0m³ GP bucket with teeth	Backing-up alarm	
manual control parking brake	GB2980-16/70-20 tire	<b>A</b>
Adjustable steering column	Engine fan guard	
A/C	Power switch	<b>B</b>
Digital combination instrument	Tool box	



## Optional Equipment

Pallet fork	<b>C</b>	Pallet fork(QC)		LED work lights	<b>A</b>
1.0m³ general purpose bucket	<b>D</b>	0.9m³ multiple purpose bucket(QC)		3rd function connector	
1.4m³ light material bucket bucket		1.0m³ general purpose bucket(QC)		Double joystick pilot control	<b>B</b>
Quick hitch	<b>E</b>	1.4m³ light material bucket bucket(QC)	<b>F</b>	Tire protect chain	

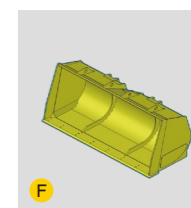
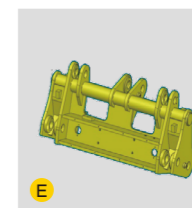
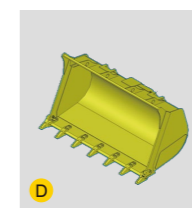
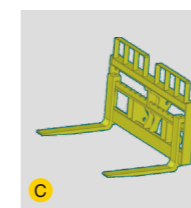

\* The right of final interpretation of the abovementioned parameters shall be reserved by SDLG. No further notice will be given in case of any change. Illustrations in the text may not always be the standard illustrations for this model.